





# SCREENING BUCKET

## BVR Series

...essential equipment for numerous applications such as selecting stones along water courses, selecting resulting materials after a demolition, reclaiming stony soil, cleaning beaches, separating organic waste in landfill sites, covering pipes in canalisation works...

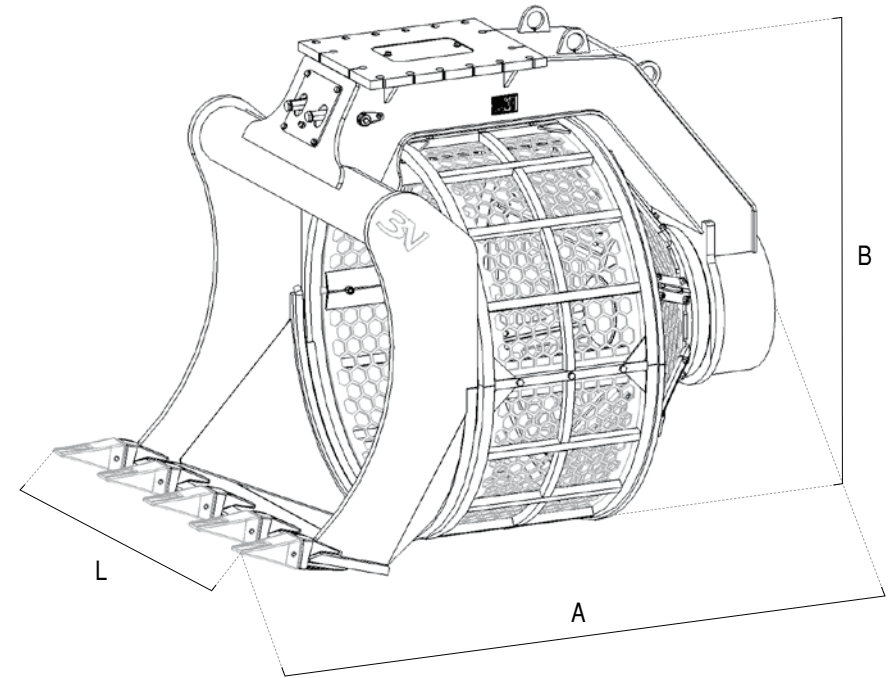

		BVR 07	BVR 08	BVR 09	BVR 12C	BVR 12C Speed	BVR 14C	BVR 14C Speed	BVR 15C	BVR 15C Speed	BVR 19C
Excavator Weight	lbs	6,615 : 11,025	11,025 : 17,640	17,640 : 26,460	28,665 : 35,280	28,665 : 35,280	37,485 : 46,305	37,485 : 46,305	48,510 : 66,150	48,510 : 66,150	68,355 : 88,200
Weight	lbs	550	770	1,520	2,910	2,910	3,460	3,460	3,990	3,990	5,770
A	inches	17,5	20,3	27,2	31,1	31,1	36,4	36,4	38,6	38,6	36,2
B	inches	31,7	36,6	41,5	57,5	57,5	65	65	74,4	74,4	78,7
L	inches	27,6	31,5	35,4	47,2	47,2	55,1	55,1	63	63	68,9
Cap. SAE	cy	0,5	0,7	0,9	1,1	1,1	1,2	1,2	1,4	1,4	1,9
Working pressure	psi	1,500 / 1,750	1,500 / 1,750	1,500 / 1,750	1,500 / 1,750	1,500 / 3,000	1,500 / 1,750	1,500 / 3,000	1,500 / 1,750	1,500 / 3,000	1,500 / 1,750
Oil flow	g/min.	8 / 13	8 / 13	13 / 19	21 / 38	38	21 / 38	38	21 / 38	38	21 / 38
Round per minute	rpm	18 / 24	18 / 24	18 / 24	18 / 24	35 / 40	18 / 24	35 / 40	18 / 24	35 / 40	18 / 24