

MARILYN SHEAR

CS Series

...destined for modern industrial demolition work sites that require substantial cutting power at considerable heights and for professionals who work in the recycling of scraps and ferrous materials. The continuous rotation, the protected cylinder, a speed multiplier valve and its interchangeable blades make it unique in its kind...

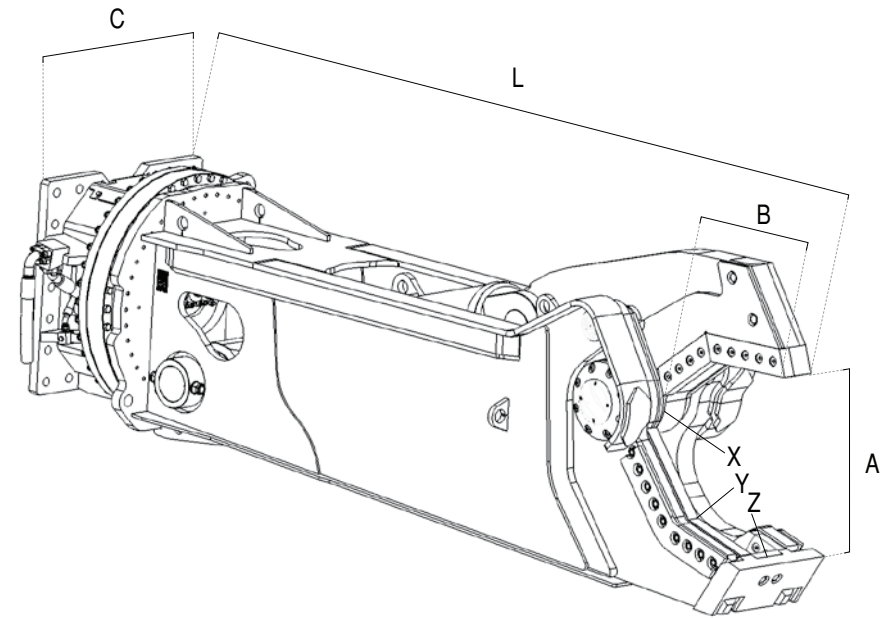

		CS 05R	CS 07R	CS 20RS	CS 30RS	CS 40RS	CS 55RS	CS 70RS	CS 90RS
Excavator weight boom position	lbs	5,510 : 8,820	8,820 : 15,435	22,050 : 35,280	37,485 : 48,510	55,125 : 66,150	66,150 : 88,200	99,225 : 121,275	154,350 : 198,450
Excavator weight bucket position	lbs	11,025 : 17,640	17,640 : 26,460	39,690 : 55,125	66,150 : 83,790	88,200 : 110,250	121,275 : 154,350	165,375 : 220,500	264,600 : 330,750
Weight	lbs	992	1,650	3,630	6,170	8,600	12,450	15,800	20,400
A	inches	13,4	15,9	21	24,2	26,8	30,7	33,3	36,2
B	inches	12,6	14	17,9	21,5	23,6	27,2	27,9	30,7
C	inches	18,1	18,1	28,1	28,1	34	39,4	43,3	47,2
L	inches	67,9	80,7	104,7	122,4	134,6	153,7	165	173,2
X	t.	125	210	270	550	600	715	875	1190
Y	t.	50	90	125	230	270	290	375	535
Z	t.	25	50	70	125	145	160	205	295
Working pressure	psi	3600	4500	4500	4900	4900	4900	4900	4900
Oil flow	g/min.	21 / 38	38 / 40	48 / 66	53 / 80	80 / 105	105 / 132	118 / 160	132 / 211
Rotation	psi / g/min.	1750 / 2,7	1750 / 2,7	2000 / 2,7	2000 / 2,7	2000 / 2,7	2000 / 7,9	2000 / 7,9	2000 / 13,2