

MK SERIES

		MK 15	MK 20	MK 25	MK 35
Excavator weight ⁽¹⁾	t.	18 : 25	25 : 35	35 : 45	45 : 60
Frame weight	lbs.	2,398	3,223	4,334	4,730
H1**	inch.	52	58	60	61
Working pressure	psi	4,500	4,500	4,500	4,500
Oil flow	g/min.	48 / 66	48 / 80	66 / 922	80 / 105
Rotation	g/min. / psi	2.6 / 1,440	2.6 / 1,440	2.6 / 1,440	2.6 / 1,440

(**) H = H1 + H2

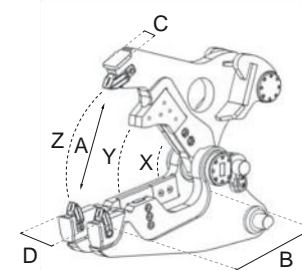
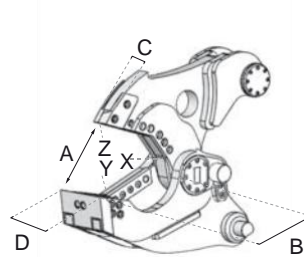
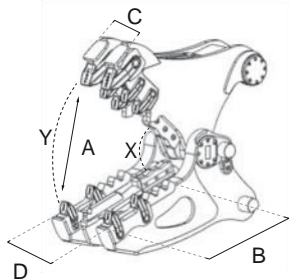
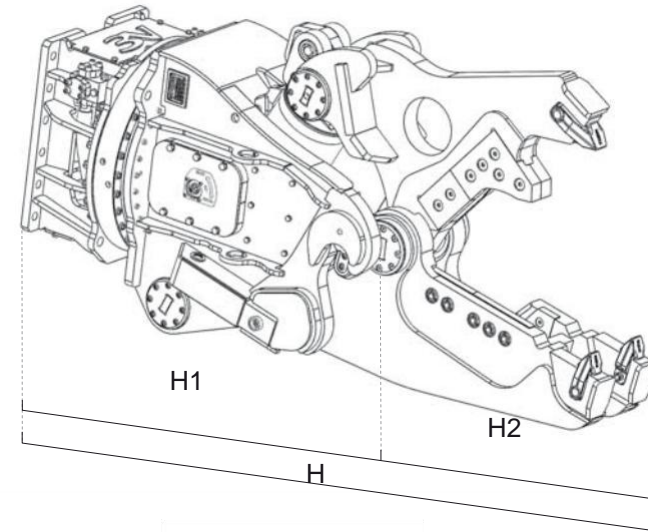

		Pulverizer Kit				Shear Kit				Combi Kit			
		MK 15	MK 20	MK 25	MK 35	MK 15	MK 20	MK 25	MK 35	MK 15	MK 20	MK 25	MK 35
Kit weight	lbs	1,716	2,222	2,640	3,575	1,562	2,090	2,552	2,959	1,782	2,376	2,750	3,718
A	inch	30	35	36	39	17	19	20	20	29	32	34	35
B	inch	26	31	32	34	19	21	22	22	28	31	32	34
C	inch	12	13	14	15	4	4	5	5	5	5	5	5
H1	inch	18	19	22	25	13	15	17	17	13	14	16	17
H2**	inch	9	10	10	10	18	20	22	17	17	19	20	20
H2**	inch	30	35	37	40	26	29	30	32	35	38	40	42
X	ton.	190	205	230	330	420	530	720	740	420	510	700	740
Y	ton.	65	80	105	115	180	230	290	315	100	125	155	175
Z	ton.	/	/	/	/	95	120	145	160	65	80	100	115
Ø max	inch	1.4	1.6	1.8	2.0	2.0	2.4	2.5	2.7	1.6	1.8	2.0	2.2
I-beam max	inch	/	/	/	/	8	14	25	16	/	/	/	/
h-beam max	inch	/	/	/	/	6	9	10	11	/	/	/	/
max	inch	/	/	/	/	/	/	/	/	/	/	/	/

(1) Excavator-equipment recommended combination

